

User Manual for OTTO HEUSS Swell Engine, Version VI  
With freely adjustable electric actuation and control of swell shutters



Otto Heuss GmbH  
Amtsgerichtsstr. 12  
35423 Lich, Germany

+49 (0) 6404 9169 0  
info@ottoheuss.com

Version 2, as of: 27.07.2015, from STW 3.78

# User Manual for OTTO HEUSS Swell Engine, Version VI

## With freely adjustable electric actuation and control of swell shutters

### Table of Contents

User Manual for OTTO HEUSS Swell Engine, Version VI With freely adjustable electric actuation and control of swell shutters..... 1

- 1 Introduction: OTTO HEUSS Swell Engine, Version VI ..... 3
- 2 Technical data..... 3
- 3 Mechanical connection ..... 3
- 4 Electric connection ..... 4
  - 4.1 Connection instructions for the organ builder ..... 4
  - 4.2 Connection instructions for the electrician ..... 5
  - 4.3 Circuit diagram ..... 6
- 5 Setup and calibration ..... 7
  - 5.1 Set the start and end position ..... 7
  - 5.2 Setup the acceleration and brake ramps ..... 10
  - 5.3 Change the speed ..... 10
  - 5.4 Reverse the direction of automatic opening/closing ..... 10
  - 5.5 Change the travel direction ..... 11
  - 5.6 Overview of the 8-way DIP switches ..... 11
  - 5.7 Setup of the acceleration curve using the **4-way DIP switch** ..... 12
  - 5.8 Inverting the acceleration curves ..... 12
- 6 Precautions and precautionary measures..... 13
- 7 Warranty..... 13
- 8 Disposal ..... 13

# User Manual for OTTO HEUSS Swell Engine, Version VI

## With freely adjustable electric actuation and controll of swell shutters

### 1 Introduction: OTTO HEUSS Swell Engine, Version VI

In order to offer to you more travel and operating possibilities of the device, we have completely revised and redesigned our tried and tested swell engine model.

The swell engine consists of the drive component and the control unit. The drive is mechanically connected with the swell shutter, the control unit is electrically connected to the swell pedal, the drive component and mains connection (230 Volts or 110 Volts).

### 2 Technical data

Force	15kg
Operating voltage	230V / 110V AC
Input power	92W at 230V AC
Travel	200mm max.

### 3 Mechanical connection

**Note:** Please ensure that the drive component of the swell engine is securely fastened to prevent damage. The movement of swell shutters may lead to very high resulting forces.

The drive component is housed in a sturdy aluminium case and mounted in a vibration-damped way. The upper and bottom sides of the case each have four bores, each of which featuring a rubber cushion for additional dampening.

The drive component is equipped with a fork head for the connection of the swell shutter. This fork head including its vibration damper may also be connected to the other side of the drive rod, thus allowing the swell engine to be used on both sides.

A swell engine drive model equipped with angle joint is available on request.

**Warning note:** Never reach into the case while the swell engine is switched on. Effective acting forces of more than 20kg!  
**Danger of crushing!**



# User Manual for OTTO HEUSS Swell Engine, Version VI

## With freely adjustable electric actuation and controll of swell shutters

### 4 Electric connection

**Note:** The swell engine must be connected to mains by a qualified electrician.

#### 4.1 Connection instructions for the organ builder

The control unit is shipped with a cable for connection to the drive component. Simply plug it into the connecting sleeve socket at the drive component. The cables for the motor are connected to clamps 14 and 15, the 10 kΩ motor potentiometer (actual value) is connected to clamps 8, 9 and 10 (see the circuit diagram).

The swell pedals potentiometer must be connected to clamps 11, 12 and 13 (according to the wiring diagram) using a three-wire **shielded cable** (3 x 0.5mm<sup>2</sup>, 50m max. length).

We recommend the use of our swell pedals with two double slide potentiometers and maintenance free linear bearing:

Swell pedal with brass foot plates	Article number: 3006-260
Swell pedal with aluminium foot plates	Article number: 3006-265

If there is a mechanical swell pedal already in place, it can be equipped with our swell pedal bearing featuring two double slide potentiometers and maintenance free linear bearing:

Swell pedal bearing with two double potentiometers	Article number: 3007-260
--	--------------------------

The three channels of the HEUSS potentiometers are configured as follows:

- Channel 1: Plus
- Channel 2: Sliding contact
- Channel 3: Minus

Connect channel 1 to clamp 11 on the control unit, channel 2 to clamp 12 and channel 3 to clamp 13. If the swell engine is required to work in the opposite direction, the sense of movement may be reversed using with dip switches on the control unit (see "[5.5 Change the travel direction](#)"). Please go through the other steps first for calibrating the swell engine.

Please use only linear potentiometers with a resistance of 10kΩ together with HEUSS swell engines.

If the swell engine has to be connected to a HEUSS SPS, only two wires must be connected to the control unit, clamp 12 has to be connected to the red output clamp on the SPS, clamp 13 has to be connected with the blue output clamp (labelled with Swell Engine or Schweller on the SPS). Clamp 11 remains not connected.

# User Manual for OTTO HEUSS Swell Engine, Version VI

## With freely adjustable electric actuation and controll of swell shutters

### 4.2 Connection instructions for the electrician

The control unit of the swell engine must be connected to the 230V or 110V mains connection (please also refer to [4.2.2 Change the input voltage](#)).

After switching-off the organ the swell engine nevertheless still needs to open or close the swell shutters. Therefore the swell engine needs a permanent power supply as well as a power supply switched in line with the organ (electric contactor for motor and organ power supply).

It is absolutely essential that both power supplies use the same phase. Failure to observe this requirement may lead to a short circuit.

Both inputs are fused (1AT) on the circuit board using a separate fused.

**Attention:** It is absolutely essential that **both power supplies use the same phase!**  
Please double-check this prior to any commissioning and/or powering up of the organ to prevent serious damage to the device caused by short circuits!

Electrical grounding: Please ground the device by connecting the protective ground wire to the screw connection located on the bottom of the circuit board.

Neutral (N) and phase (L) must be connected to the connection block on the left in the control unit as follows:

- Neutral (N): Clamp 7
- Permanent phase (L): Clamp 6
- Switched phase (L): Clamp 5

#### 4.2.2 Change the input voltage

The swell engine works with an input voltage of either 230V or 110V. The input voltage is pre-set at the factory. If you should need to use the other input voltage option, you have to change the wire connected to clamp 3 on the control unit.

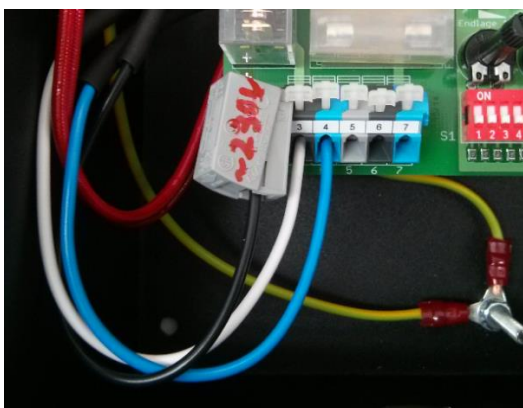

If the swell engine is shipped for 230V operation and you need 110V, remove the black wire from clamp 3 and replace it with the white wire (marked "110V") you will find mounted below the circuit board. Make sure to insulate the black wire to prevent short circuits.

If the swell engine is shipped for 110V operated and you need 230V, remove the white wire from clamp 3 and replace it with the black wire (marked "230V") you will find mounted below the circuit board. Make sure to insulate the white wire to prevent short circuits.

(The image shows the white wire connected for operation with input voltage of 110 Volts)

# User Manual for OTTO HEUSS Swell Engine, Version VI

## With freely adjustable electric actuation and controll of swell shutters

### 4.3 Circuit diagram

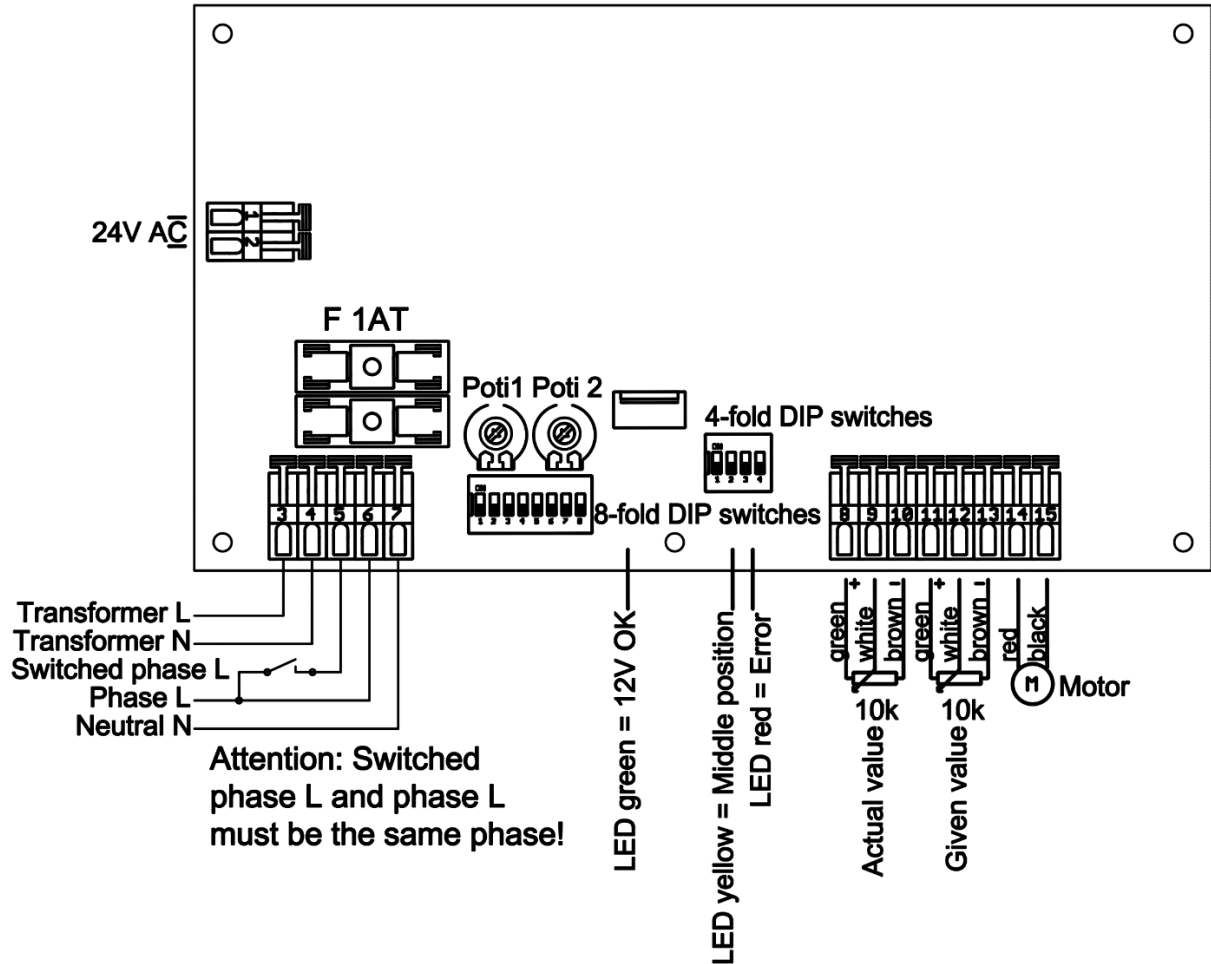

If the swell engine has to be connected to a HEUSS SPS, only two wires must be connected to the control unit, clamp 12 has to be connected to the red output clamp on the SPS, clamp 13 has to be connected with the blue output clamp (labelled with Swell Engine or Schweller on the SPS). Clamp 11 remains not connected.

# User Manual for OTTO HEUSS Swell Engine, Version VI

## With freely adjustable electric actuation and controll of swell shutters

### 5 Setup and calibration

Travel, sense of travel, speed and acceleration curve can be adjusted on the circuit plate of the control unit using the two potentiometers and the DIP switches.

If you calibrate the swell engine for the first time, please follow this manual step by step.

**Note:** Do not use the actual value potentiometer on the motor pinion to calibrate the travel. Please use the DIP switches and the two potentiometers 1 and 2 located in the housing of control unit. **The actual value potentiometer on the motor must not be changed.**

The swell engine has a safety switch-off, which disables the motor if too much force is applied. This failure is shown with a red LED on the control unit.

This failure can be reset by switching off the power und turning it on again.

#### 5.1 Set the start and end position

Both ends of the push rod are marked with a position number. As delivered, the fork head connector is fitted on position 1.

Make sure that neither the swell engine nor the swell shutter itself will run or press against any of the stops to prevent damage to the swell shutter or the swell engine.

Please calibrate the swell engine first roughly without a connected swell shutter, to prevent damages.

# User Manual for OTTO HEUSS Swell Engine, Version VI

## With freely adjustable electric actuation and controll of swell shutters

### 5.1.1 Standpoints of the drive component

With the swell pedal in the closed position (the pedal is tilt back), the push rod is extended in the direction position 1:

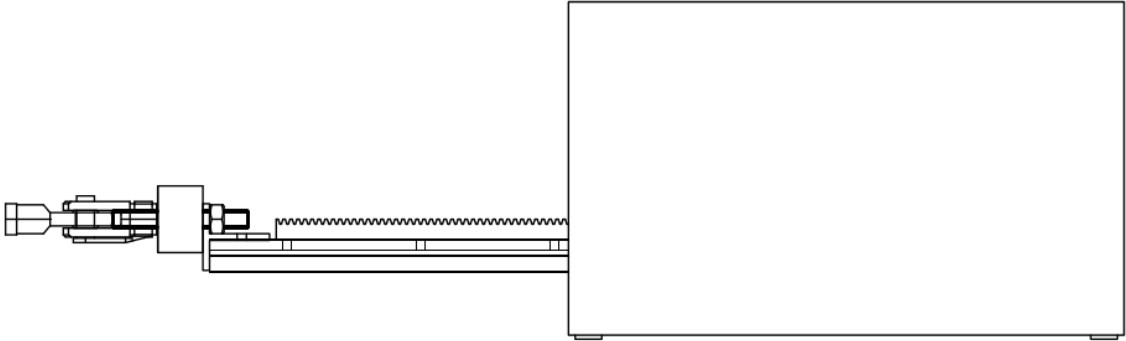

With the swell pedal in the opened position, the push rod is extended in the direction position 2, the fork head connector is pulled into the metal case:





# User Manual for OTTO HEUSS Swell Engine, Version VI

## With freely adjustable electric actuation and controll of swell shutters

### 5.1.2 Adjust the "closed" position

The closed position has to be adjusted as follows:

Bring the swell pedal in the closed position. The push rod should now move towards position 1.

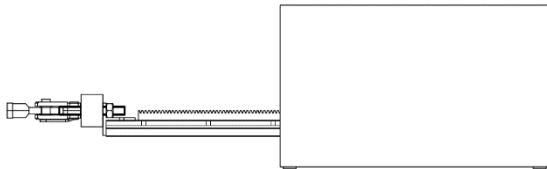

Now switch on the fifth of the eight DIP-Switches below the two potentiometers. Perhaps the push rod is already moving to another position.

Adjust the push rod using potentiometer 1.

After reaching the desired position, switch-off the DIP-Switch. The setting is saved.

### 5.1.3 Adjust the "opened" position

The opened position has to be adjusted as follows:

Bring the swell pedal in the opened position. The push rod should now move towards position 2.



Now switch on the sixth of the eight DIP-Switches below the two potentiometers. Perhaps the push rod is already moving to another position.

Adjust the push rod using potentiometer 2.

After reaching the desired position, switch-off the DIP-Switch. The setting is saved.

# User Manual for OTTO HEUSS Swell Engine, Version VI

## With freely adjustable electric actuation and controll of swell shutters

### 5.2 Setup the acceleration and brake ramps

The acceleration and brake ramps are pre-set at the factory to allow for maximum speed. If you would like to change this, you can do so by using the DIP switches and the potentiometers. Start with the acceleration ramp:

- Set DIP switch 3 to position “On”.
- Calibrate the desired acceleration characteristics using potentiometer 1.
- Set DIP switch 3 back to position “Off”.

Adjust the brake ramp in a similar way:

- Set DIP switch 4 to position “On”.
- Calibrate the desired brake characteristics using potentiometer 2.
- Set DIP switch 4 back to position “Off”.

### 5.3 Change the speed

You may also wish to change the speed used by the engine to open and/or close the swell shutter. For speed adjustment please use DIP switches 7 and 8 according to the table below:

DIP 7	DIP 8	Speed
off	off	100%
off	on	75%
on	off	50%
on	on	25%

The two DIP switches remain in this position permanently.

### 5.4 Reverse the direction of automatic opening/closing

The swell engine features a function for the automatic opening and/or closing of the swell shutter taking place when the organ is switched off. The direction of this opening or closing can be changed using DIP switch 1. To reverse the direction, set DIP switch 1 to opposite position.

# User Manual for OTTO HEUSS Swell Engine, Version VI

## With freely adjustable electric actuation and control of swell shutters

### 5.5 Change the travel direction

Of course it is also possible to use the swell engine with an inverted travel direction. This change should be done **after** the complete calibration.

First adjust the start and end position as described earlier, ignore that the swell engine in this case is working in the wrong direction.

After both positions are adjusted, switch-on DIP-Switch 2 below the potentiometers, this inverts the travel direction. Leave this switch in its position afterwards.

To recalibrate the swell engine, switch-off this switch again and switch it back on afterwards.

**The acceleration curves turn with the travel direction. To invert them, the fourth of the 4-way DIP-Switches must be switched-on as described in [“5.8 Inverting the acceleration curves”](#)**

### 5.6 Overview of the 8-way DIP switches

The 8-way DIP switches are configured to allow for various functions as follows:

#### DIP switch 1

Use this switch to set the direction of the automatic opening or closing of the swell shutter.

#### DIP switch 2

Use this switch to reverse the travel direction of the swell engine.

#### DIP switch 3

Use this switch to set the acceleration ramp.

#### DIP switch 4

Use this switch to set the brake ramp.

#### DIP switch 5

Use this switch to calibrate the starting position.

#### DIP switch 6

Use this switch to calibrate the end position.

#### DIP switches 7 and 8

Use these switches to adjust the speed of the swell engine.

# User Manual for OTTO HEUSS Swell Engine, Version VI

## With freely adjustable electric actuation and controll of swell shutters

### 5.7 Setup of the acceleration curve using the 4-way DIP switch

The acceleration curve may be adjusted (in binary code) using the 4-way DIP switches on the control unit:

DIP 1	DIP 2	DIP 3	Curve
off	off	off	Linear
off	off	on	Curve 1
off	on	off	Curve 2
off	on	on	Curve 3
on	off	off	Curve 4
on	off	on	Curve 5
on	on	off	Curve 6
on	on	on	Curve 7

**Acceleration curves**

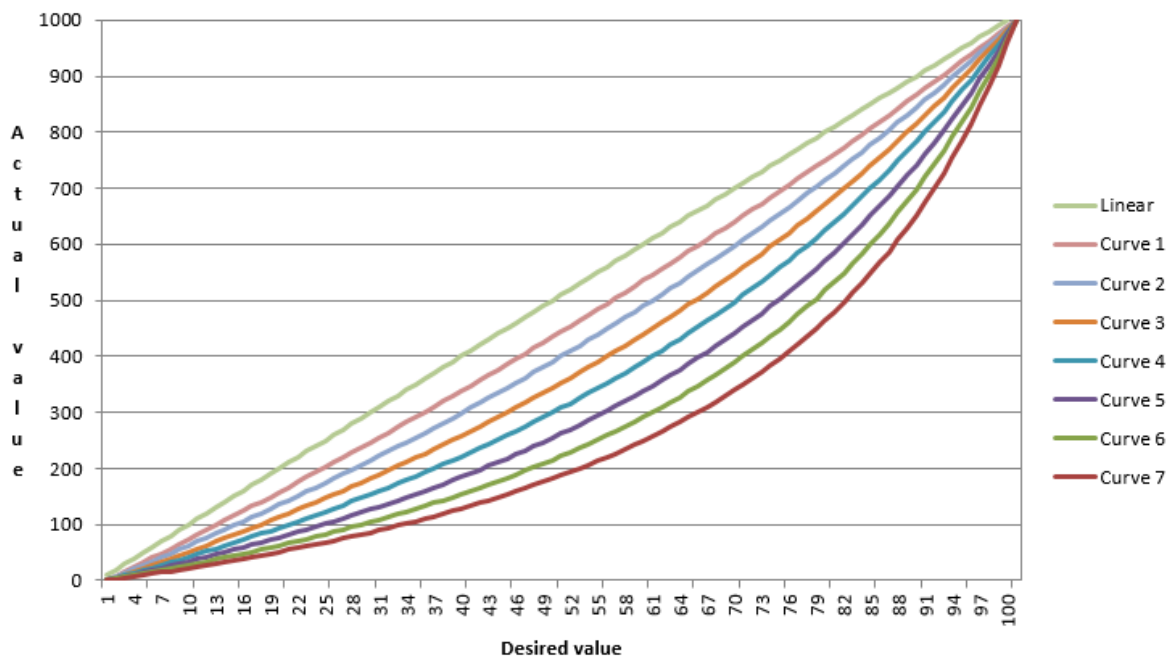

### 5.8 Inverting the acceleration curves

This paragraph refers to „[5.5 Change the travel direction](#)“.

If the travel direction of the swell engine is changed as described earlier, it is possible to also invert the acceleration curves by switching on DIP-Switch 4 four. The acceleration curve will work opposed, if it is not changed with the travel direction.

# User Manual for OTTO HEUSS Swell Engine, Version VI

## With freely adjustable electric actuation and controll of swell shutters

### 6 Precautions and precautionary measures

To ensure a safe and optimum operation, please note the following precautionary measures:

- Do not expose the system to heat, dust or humidity.
- Please ensure that the drive component of the swell engine is securely fastened, to prevent damage. The movement of swell shutters may lead to high resulting effective forces.
- An organ is an electrical device and needs to be installed in compliance with all applicable standards and regulations.
- Avoid strong vibrations during transport to prevent damage of the electrical parts.
- Do not install the device near any devices that produce or emit high-frequency electromagnetic waves, like television devices, radio receivers, microphone systems/transmitters, broadcasting towers, radio masts etc.
- It is crucial to make sure that no liquids or metal cuttings or objects of any kind get into the inside of the unit as they may cause serious damage.
- Do not perform any unauthorized modifications or repairs on the electrical system.
- In case of a defect, please refer to the manufacturer or your organ builder.
- Never reach into the case while the swell engine is switched-on.

Effective acting forces of more than 20kg!

**Danger of crushing!**



### 7 Warranty

- Otto Heuss GmbH grants a two years warranty after delivery.
- Otto Heuss GmbH is not responsible for any damage caused by improper handling, use and/or operation.
- Otto Heuss GmbH shall not be held liable for any loss and/or damage incurred in connection with concerts, performances and/or events cancelled and/or negatively affected.

### 8 Disposal

Do not dispose of electrical equipment, batteries etc. together with your household waste. Dispose of properly at your local collection points for special waste.

Collect and dispose of batteries and other electrical equipment in compliance with applicable local legislation, rules and regulations.

