

Whatever you touch and hear
in organ building: you'll always come
across on of our ideas.



HEUSS-Direct pallet magnet

The new improved HEUSS valve disc magnet has been developed from the service life standpoint too. The plastic bearing bush used in the past has been replaced with a self-lubricating, highly wear resistant and tested bronze one. The magnet frame is of solid iron and has black rust resistant zincing. The spool, disc and thrust bearing are made of high quality black polyamide 66 with 30% glass fibre making them UV, weather, heat, shape and age resistant as well as very rugged.

The HEUSS valve disc magnet includes the HEUSS easy disc replacement system. Each disc fits any magnet and can be replaced in seconds. The discs are available in six different diameters. Thanks to the integrated stiff ball head, the disc is always in contact with the channel base. The disc itself has felt and leather covering to ensure leak proofing.

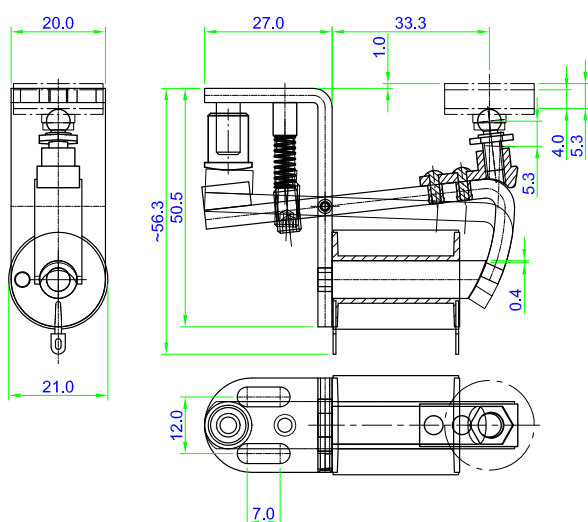

Order number	Voltage	Ampere	Resistance
5008-2XX	14V=	0,24A	58
5008-4XX	24V=	0,18A	135

Ø mm	XX
19	10
21	20
25	30
30	40
35	50
40	55

The pallet discs can be set to the "Armature to core" position. In practice, this means that the magnet has a very high tensile power if optimally set. A fine thread setting is sited between the armature and the pallet disc.

Spark suppression and spiral connecting cable are installed.

For quick and easy installation, we recommend the 5008-290 installation aid to save time in installing and aligning.

